

惠州市九紫电子科技有限公司

SAMPLE APPROVAL SHEET 样品承认书

Client Name 客户: 京恒腾伟 (惠州)电子科技有限公司
Client P/N 客户料号: _____
JiuZi P/N 九紫料号: C0-02PL-G
Article 品名规格: (MX axis connector) MX 轴连接器
Remark 备注: 连接器紫色/端子接触面镀金/带固定脚

SUPPLIER APPROVAL 供应商确认:

制作 (Edited by)	审核 (Checked by)	核准 (Approved by)	送样日期 (Deliver date)
Mark	吴长根	廖其田	2022.06.27

CUSTOMER APPROVAL 客户承认:

承认 (Tested by)	审核 (Checked by)	核准 (Approved by)	承认日期 (Accept date)

地址: 广东省惠州市博罗县圆洲镇上南村上南工业区
电话: +86-0752-6699228

1. General specification 基本事项

1.1 Product category 产品种类 Connector: 连接器

1.2 Switch rating 额定值 : 12V AC/DC max. 2V DC min. 10mA AC/DC max. 10μA DC min.

1.3 Operation temperature range 使用温度试验范围: - 40 ~ + 70°C

1.4 Storage temperature range 保存温度范围 : - 40 ~ + 70°C

1.5 Suggested storage period 贮存期限 : about 6 months 最多六个月

Require the tin part on the switch terminals should keep good after storage guarantee date

要求贮存期后开关端子部分上锡仍然良好

1.6 Appearance and dimensions 外形及尺寸: See outside drawing page 见外形尺寸图

1.7 Standard condition Unless otherwise specified, the test and measurements shall be carried out as follows:

标准状态 除非另有说明, 试验和测量应如下进行

Ambient temperature 温度 : 10°C-30°C

Relative humidity 相对湿度 : 45 ~ 85

Air pressure 气压 : 86 ~ 106kPa(860~1060mbar)

However, if doubt arises on the decision based on the measured

Values under the above-mentioned conditions, the following conditions shall be employed:

但是在对判定产生疑义时, 按下述状态实施:

Ambient temperature 温度: 20±2°C Relative humidity 相对湿度: 90±5%

Air pressure 气压: 86 ~ 106kPa (860~1060mbar)

2. Performance 性能

2.1 Electrical characteristics 电气性能

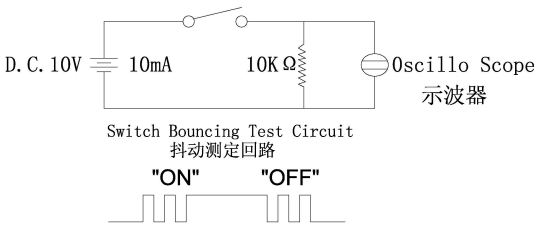
No.	Item 项目	Test condition 试验条件	Performance 规格
2.1.1	Contact resistance 接触电阻	Push force: (Operation force) x 2. 测定时的负荷: 操作方向动作力基准值的2倍。 Measurement tool : Contact resistance meter 测定器: 微电流接触电阻计(1kHz, 20mV, 5~50mA)	Initial contact resistance(初始值) 200mΩ Max After Environmental Test (环境测试后) 500mΩ Max After Life Test(寿命测试后) : 2Ω Max
2.1.2	Insulation resistance 绝缘电阻	DC. 100V(Between terminals) (端子间)	100MΩ min 100MΩ 以上
2.1.3	Withstand voltage 耐电压	AC 500V for 1 min (Between terminals) (端子间)	No insulation destruction. 无绝缘破坏.
2.1.4	Bouncing 触点抖动	Operation speed : 3~4 times/s 操作速度: 每秒3~4次 Oscilloscope 示波器 Switch Bouncing Test Circuit 抖动测定回路  Switch Bouncing Test Circuit 抖动测定回路 "ON" "OFF"	ON:5ms max 以下 OFF:5ms max以下

2.2 Mechanical Characteristics 机械性能

No.	Item 项目	Test condition 试验条件	Performance 规格
2.2.1	Mating force 插入力	At 16in/minute.actuation speed 16英寸/分钟的驱动速度	Mating force 插入力 3KG Max
2.2.2	Unmating force 拔出力	At 16in/minute.actuation speed 16英寸/分钟的驱动速度	Unmating force 拔出力 100gf Min
2.2.3	Shock 耐冲击性	Measure after test at a condition below 在下列条件下进行测试后的量度 Peak acceleration:80G 冲击加速度:80G Test time-6direction ,each 3 times total 18 times 测试次数-6 个方向, 各3次共计18 次。	No.2.1 and 2.2.1 to2.2.4 shall be satisfied 第2.1 及2.2.1—2.2.2 都应符合要求
2.2.4	Life test 寿命测试	1) No load 无负载 2) Insertion force: upper limit of operating specification value 插入力: 操作规格值的上限 3) Life test: 5000 Min 寿命: 5000次以上	Contact resistance 2Ω Max 接触电阻 2Ω Max以下 Bouncing: 10 ms max 触点抖动: 10 毫秒以下

2.3 Climatic characteristics 耐候性能

No.	Item 项目	Test condition 试验条件	Performance 规格
2.3.1	Cold test 耐寒性	1) Temperature : - 40±2℃ 温度: - 40±2℃ 2) Duration of test: 96h 持续时间: 96 小时 3) Take off a drop water 去掉水珠 4) Standard conditions after test : 1h 试验后的放置条件: 1 小时	Contact resistance 200mΩ max No. 2.1.2 to 2.1.4 and No. 2.2.1 to 2.2.2 shall Be satisfied 接触电阻 200mΩ 以下 满足2.1.2 到2.1.4 项、2.2.1 到2.2.2 项.
2.3.2	Soldering heat test 耐焊接热	端子焊接部分浸入焊炉, 焊炉温度 260±5℃, 焊接时间 5±1 秒。(焊接时不可于端子施加外力)。 Terminals shall be dipped in the solder bath at 260±5℃ for 5±1 seconds without additional force for terminals.	No damage (electrical and mechanical) 无异常。 (电气、机械特性)

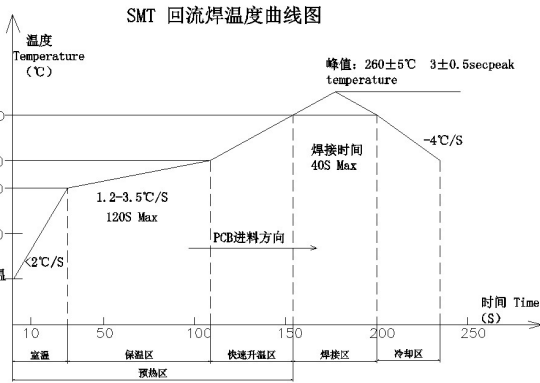
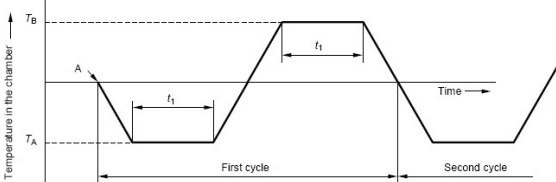
<p>2.3.3</p>	<p>Solderbility 可焊性</p>	<p>After sprated flux / 涂上助焊剂后 temperature :260± 5°C / 温度: 260± 5°C soldering time :3±0.5 sec/ 焊接时间:3±0.5 秒</p>  <p>The graph shows a temperature profile for SMT reflow soldering. The y-axis is Temperature (°C) from 100 to 230. The x-axis is Time (S) from 0 to 250. The profile starts at room temperature (室温), rises at 2°C/S to 150°C at 10s, then at 1.2-3.5°C/S to 180°C at 100s (120s Max). It then rises to a peak of 260±5°C at 150s (3±0.5s peak temperature). The peak is held for 40s (40s Max) before cooling at -4°C/S to 180°C at 200s, and finally to 100°C at 250s. The profile is divided into four zones: 预热区 (Preheat), 快速升温区 (Rapid Heating), 焊接区 (Soldering), and 冷却区 (Cooling). PCB进料方向 (PCB feeding direction) is indicated by an arrow pointing right.</p>	<p>70% or more of surface area of the portion immersed in solder shall be covered by new solder / 70% 或更多的浸焊面能被焊锡覆盖.</p>
<p>2.3.4</p>	<p>Heat test 耐热性</p>	<p>1) Temperature : 70±2°C 温度: 70±2°C 2) Duration of test: 96h 持续时间: 96 小时 3) Standard conditions after test : 1h 试验后的放置条件: 1 小时</p>	<p>Contact resistance 200mΩ max No. 2.1.2 to 2.1.4 and No. 2.2.1 to 2.2.2 shall Be satisfied 接触电阻 200mΩ 以下 满足2.1.2 到2.1.4 项、2.2.1 到2.2.2 项.</p>
<p>2.3.5</p>	<p>Temperature cycle 温度循环</p>	<p>1) Test cycles :2 cycles 试验周期: 2 个周期 2) Cycle time: 8H 循环总时间: 8小时 3) Parameter: TA:-40°C TB:70°C t1=3H 参数: TA:-40°C TB:70°C t1=3H 4) Standard conditions after test : 1h 试验后的放置条件: 1 小时</p>  <p>The graph shows a temperature cycle between TA and TB. The y-axis is Temperature in the chamber, and the x-axis is Time. The cycle consists of two identical cycles. Each cycle starts at TA, rises to TB, holds for time t1, and then returns to TA. The first cycle is labeled 'First cycle' and the second is 'Second cycle'. Points A and B are marked on the temperature curve.</p>	<p>Contact resistance 200mΩ max No. 2.1.2 to 2.1.4 and No. 2.2.1 to 2.2.2 shall be satisfied 接触电阻 200mΩ 以下 满足2.1.2 到2.1.4 项、2.2.1 到2.2.2 项.</p>
<p>2.3.6</p>	<p>Humidity test 耐湿性</p>	<p>1) Temperature : 70±2°C 温度: 70±2°C 2) relative humidity: 90~95% 相对湿度:90~95% 3) Duration of test: 96h 持续时间: 96 小时 3) Take off a drop water 去掉水珠 5) Standard conditions after test : 1h 试验后的放置条件: 1 小时</p>	<p>Contact resistance 200mΩ max No. 2.1.2 to 2.1.4 and No. 2.2.1 to 2.2.2 shall Be satisfied 接触电阻 200mΩ 以下 满足2.1.2 到2.1.4 项、2.2.1 到2.2.2 项.</p>

2.3.7	盐雾实验 Salt Mist Test	<p>试件在下述实验后测量：</p> <ol style="list-style-type: none"> 1. 温度：35±5°C 2. 盐溶液浓度：5±1%（质量百分比）， 3. 试验时间：24 小时， 4. 试验后，将盐沉积物用水冲掉。 <p>The switch shall be checked after following test:</p> <ol style="list-style-type: none"> 1. Temperature: 35±5°C 2. Salt solution: 5±1%(Solids by mass) 3. Duration: 24 hours, 4. After immersing, salt deposit shall be removed by running water. 	<p>Contact resistance 200mΩ max</p> <p>No. 2.1.2 to 2.1.4 and No. 2.2.1 to 2.2.2 shall Be satisfied</p> <p>接触电阻 200mΩ以下 满足2.1.2 到2.1.4 项、2.2.1 到2.2.2 项。 (盐雾后非镀金部位外观不作为判定依据)</p>
-------	------------------------	--	--

3. Recommended PCB Layout 推荐的 PCB 安装焊盘规格
(Single faceboard TT=1.6mm)

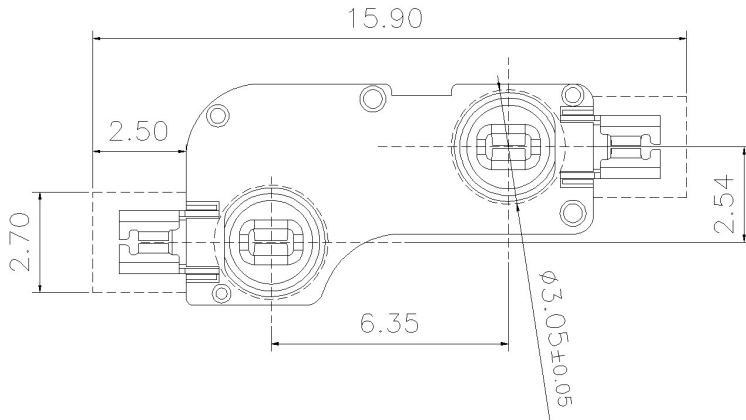

4 .Packaging 包装

Packaging type: 10Tray, 20000Pcs/Carton. 包装方式:10/盘, 20000Pcs/箱.

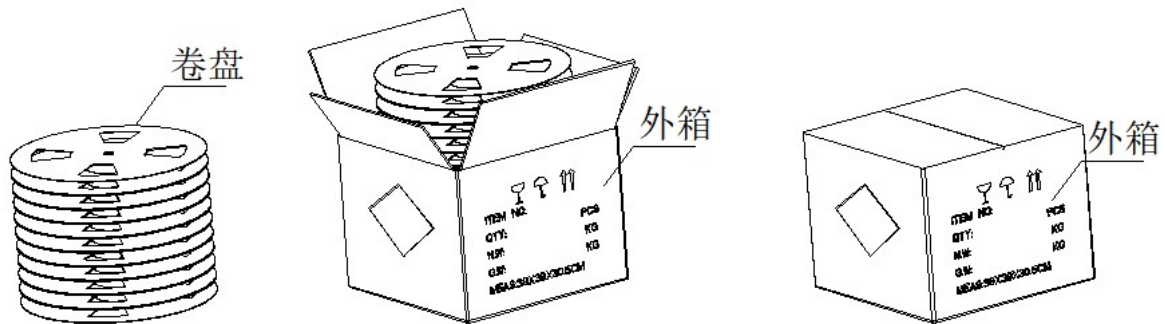

4. Precaution 注意事项

4.1 Reflow soldering conditions 回流焊条件

ITEM 项目	CONDITION 条件	
Preheating zone 预热区	Heating zone 升温区	Speed<2°C/S, Preheating time15 S Max, temperture150°C 速度<2°C/S, 预热时间15 S 最多, 温度150°C
	Heatpreservation area 保温区	Speed1.2~3.5°C/S, Preheating time120 S Max, temperture180°C 速度1.2~3.5°C/S, 预热时间120 S 最多, 温度180°C
	Fast heating zone 快速升温区	Speed3.5~4.5°C/S, Preheating time140 S Max, temperture230°C 速度3.5~4.5°C/S, 预热时间140 S 最多, 温度230°C
Weld area 焊接区	Welding time 40 S Max ,welding temperature peak value,3 sec Max. 焊接时间40 S 最多, 焊接温度峰值260°C 最大, 3 S 最多	
Area of flux 助焊剂的面积	1/2 max of P. W. B. thickness 印刷基板厚度的1/2 以内	
Temperature of solder 焊锡温度	260±5°C 260±5°C	
Soldering number 浸焊次数	Within 2 times (But should bring down heat of the first soldering) 2 次以内 (但应把第一次焊锡的温度降下来)	
Printed wiring board 印刷基板	Single sided copper-clad laminates 单面铜箔	

1) After switches were soldered, please be careful not to clean switches with solvent

开关浸焊后, 注意不要用溶剂清洗.

2) In the case of using soldering iron, soldering conditions shall be 350°C max and 3 sec. max

在使用烙铁的情况下, 焊锡温度应在350°C 以下, 3 秒以内.

3.2 Note(注意点)

1) Please be cautious not to give excessive static load connector.

注意不要施加超负荷的压力或晃动连接器.

2) Please be careful not to pile up P. W. B. after switches were soldered.

开关焊接以后, 印刷基板注意不要叠放.

3) Preservation under high temperature and high humidity or corrosive gas should be avoided

Especially. When you need to preserve for a long period, do not open the carton.

保管时尤其应注意避开高湿高温和有腐蚀性气体的环境. 如需长时间保存, 请不要打开包装箱.

4) The standard storage period is 3 months, with maximum up to 6months, preferably to be used as soon as possible. After opening the package, you should put the remaining switches in a plastic bag to prevent from damp and corrosive gas.

保存标准为 3 个月, 限度为 6 个月以内, 请尽早使用. 打开包装后, 有剩余品时, 应将剩余部分以胶袋包装好以同外界隔离, 请进行合适的防湿, 防腐蚀气体等处理后进行保管.

5) The specification is the technical consensus between the customer and our company's products. Any content inconsistent with the specification in other relevant data is invalid

该规格书为客户与我公司产品在技术方面的共识, 其他相关数据上与该规格书不一致的内容都是无效的.

6) If customer issue purchase orders without confirmation by signature of this specification after receipt, such confirmation will be considered as granted upon receipt of the first purchase order.

如果顾客收到规格书后没有信息反馈而直接向我公司订货, 我们将认为贵客已接受此规格书.

7) If there is no order or no request for new specification after 1 year upon this specification is issued, the specification will be regarded as invalid.

本产品规格书从生效日起 1 年后, 如果没有订货或再次申请最新规格书时请做无效处理.

8) Products meet the ROHS environmental management substances control standards

产品满足 ROHS环境管理物质管制标准

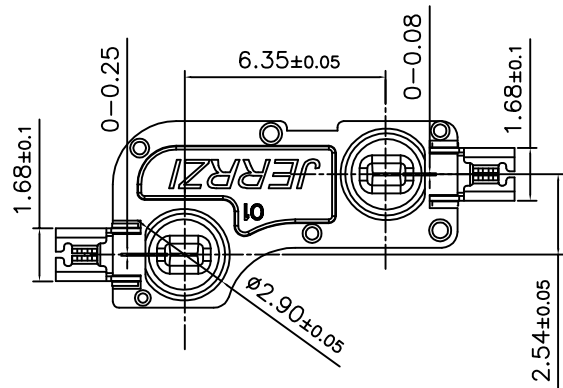
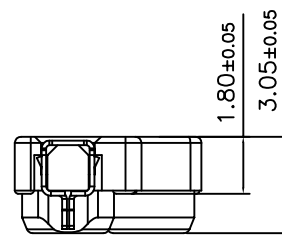
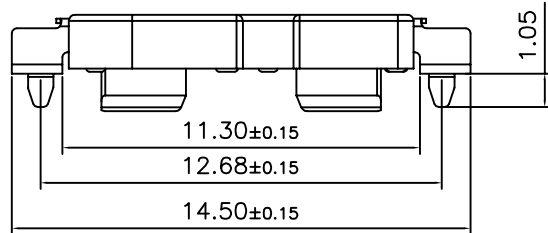
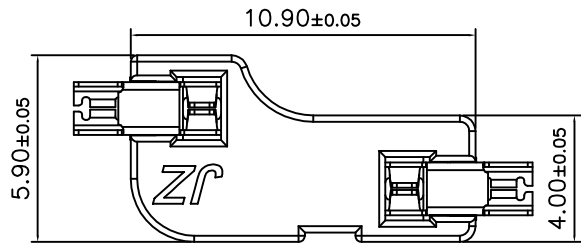

Technical parameters:

Voltage: 12 VAC/DC max 2 VDC min
 Current: 10mA AC/DC max 10mA DC min
 Insulation Resistance: 100MΩ at 100V(min)
 Initial Contact Resistance: 200mΩ max
 Bounce Time: ≤5msec
 Capacitance: <2pF (at 1kHz)
 Operating Temperature: -10° C to +70° C
 Storage Temperature: -40° C to +70° C
 Solderability: Wave solder, 5 seconds at 260±5° C
 Insertion Force: 3.0Kg Max
 Pull out Force: 100gf Min
 Operating life: 5,000 cycles (Used with MX shaft)

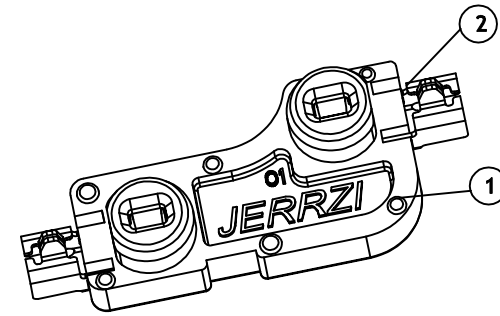

2	Connector	/	2PCS	Copper	Surface gold tin plating	/
1	Baseshell	/	1PCS	PA	Purple	/
序号 ITEM	零件 PART NAME	端子编号 TER NO.	用量 QTY.	材质 MATERIAL	电镀/颜色 FINISHING	备注 REMARK

产品结构表 (BOM)

制图 DRAWIN	Mark	2022.06.17	比例 SCALE	1:1	惠州九紫电子科技有限公司	
审核 CHECKED			张数 SHEET	1/1		
核准 APPROVE			单位 UNIT	mm	名称 TITLE	MX轴连接器(带固定脚)
一般公差 TOLERANCE	30 <L	±0.80	角度 ANGLES	料号 P/N NO.	CO-02PL-G	
	10 <L ≤ 30	±0.50	±3.0°	纸张 SIZE	A4	角法 PROJ.
	5 <L ≤ 10	±0.30				
	L ≤ 5	±0.20				
版本 REV.	ECN 编号 ECN NO.	日期 DATE	变更内容 DEFINITION	修改 DRAW	核准 APPROVE	工程图 ENG DRAW

A / 2022.06.17

新发行

版本
REV.

ECN 编号
ECN NO.

日期
DATE

变更内容
DEFINITION

修改
DRAW

核准
APPROVE

工程图
ENG DRAW

A

B

C

D

E

F

G

H